

# R-KER-II Hybrid resin with Threaded Rods

High strength and versatile application in cracked and non-cracked concrete with threaded rods.

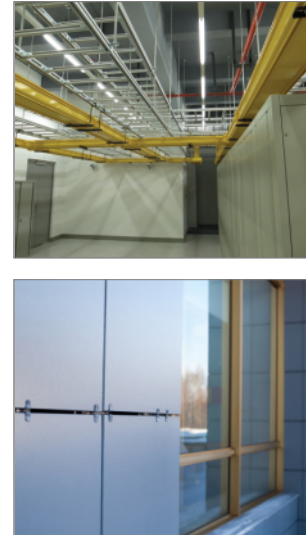

## Approvals and Reports

- ETA-17/0594

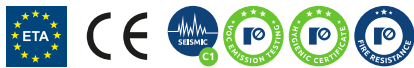

## Product information

### Features and benefits

- Approved for use with threaded rods in cracked and non-cracked concrete
- Suitable for use in dry or wet substrates and water filled holes
- For faster curing winter version of the resin can be used
- Approved for 3 types of hole cleaning (including use of dustless drill bit)
- Special nozzle with longer mixer for more comfortable and precise application
- Suitable for multiple use. Partly used product can be reused after fitting new nozzle
- Very high load capacity

### Applications

- Curtain walling
- Balustrading
- Handrails
- Canopies
- Cable conduits and trays
- Fencing & gates manufacturing and installation
- Pipework/ductwork supports
- Platforms
- Pipelines systems
- Passenger lifts
- Safety barriers
- Formwork support systems
- Structural steelwork
- Street lamps
- Racking systems
- Barriers

### Base materials

Approved for use in:

- Cracked concrete C20/25-C50/60
- Non-cracked concrete C20/25-C50/60

## Installation guide

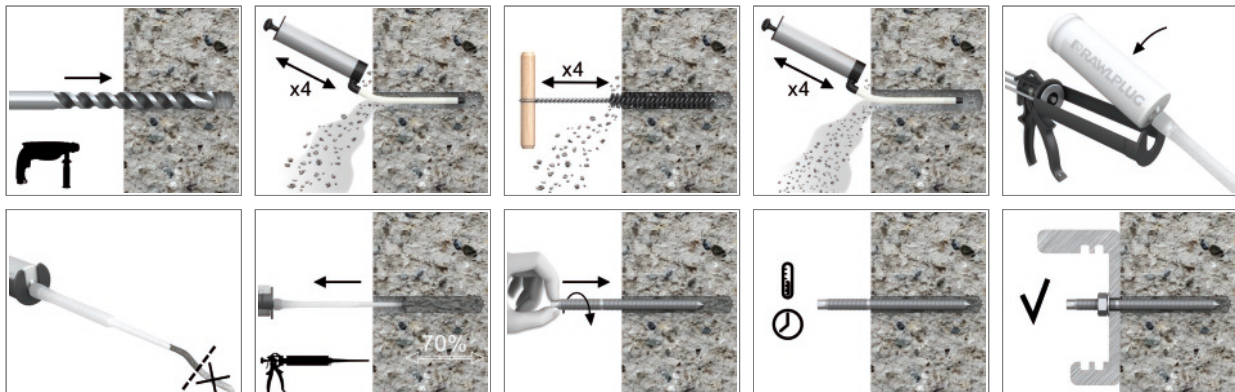

## Product information

1. Drill hole to the required diameter and depth for stud size being used.
2. Clean the hole thoroughly with brush and hand pump at least four times before installation.
3. Insert cartridge into gun and attach nozzle.
4. Dispense to waste until even colour is obtained (min. 10 cm).
5. Insert the mixer nozzle to the bottom of the drill hole and inject resin, slowly withdrawing the nozzle as the hole is filled to 70% of its depth.
6. Immediately insert the stud, slowly and with slight twisting motion. Remove any excess resin around the hole before it sets and leave it undisturbed until the curing time elapses.
7. Attach fixture and tighten the nut to the required torque.

Product Code	Resin	Description / Resin Type	Volume
			[ml]
R-KER-II-300	R-KER-II	R-KER II Hybrid Resin	300
R-KER-II-345			345
R-KER-II-400			400
R-KER-II-300-S	R-KER-II-S	R-KER II Hybrid Resin for High Temperature (Summer) / Slow Cure Styrene Free Hybrid Resin	300
R-KER-II-400-S			400
R-KER-II-300-W	R-KER-II-W	R-KER II Hybrid Resin for Low Temperature (Winter) / Rapid Cure Styrene Free Hybrid Resin	300
R-KER-II-345-W			345
R-KER-II-400-W			400

Size	Product Code	Resin	Description / Resin Type	Volume
				[ml]
Ø32	R-KER-II-300	R-KER-II	R-KER II Hybrid Resin	300
	R-KER-II-345			345
	R-KER-II-400			400
Ø40	R-KER-II-300-S	R-KER-II-S	R-KER II Hybrid Resin for High Temperature (Summer) / Slow Cure Styrene Free Hybrid Resin	300
	R-KER-II-400-S			400
Ø32	R-KER-II-300-W	R-KER-II-W	R-KER II Hybrid Resin for Low Temperature (Winter) / Rapid Cure Styrene Free Hybrid Resin	300
	R-KER-II-345-W			345
	R-KER-II-400-W			400

### R-STUDS

Size	Product Code			Anchor		Fixture		
	Steel class 5.8	Steel class 8.8	Steel grade A4	Diameter	Length	Hole diameter	Max. thickness $t_{fix}$ for:	
				d	L	$d_f$	$h_{nom, min}$	$h_{nom, max}$
				[mm]	[mm]	[mm]	[mm]	[mm]
M8	R-STUDS-08110	R-STUDS-08110-88	R-STUDS-08110-A4	8	110	9	40	-
	R-STUDS-08160	-	R-STUDS-08160-A4	8	160	9	90	-
M10	R-STUDS-10130	R-STUDS-10130-88	R-STUDS-10130-A4	10	130	12	58	-
	R-STUDS-10170	-	R-STUDS-10170-A4	10	170	12	98	-
	R-STUDS-10190	-	R-STUDS-10190-A4	10	190	12	118	-
M12	R-STUDS-12160	R-STUDS-12160-88	R-STUDS-12160-A4	12	160	14	85	-
	R-STUDS-12190	-	R-STUDS-12190-A4	12	190	14	115	-
	R-STUDS-12220	-	R-STUDS-12220-A4	12	220	14	145	-
	R-STUDS-12260	-	R-STUDS-12260-A4	12	260	14	185	-
	R-STUDS-12300	-	R-STUDS-12300-A4	12	300	14	225	45
M16	R-STUDS-16190	R-STUDS-16190-88	R-STUDS-16190-A4	16	190	18	111	-
	R-STUDS-16220	R-STUDS-16220-88	R-STUDS-16220-A4	16	220	18	141	-
	R-STUDS-16260	-	R-STUDS-16260-A4	16	260	18	181	-
	R-STUDS-16300	-	R-STUDS-16300-A4	16	300	18	221	-
	R-STUDS-16380	-	R-STUDS-16380-A4	16	380	18	301	41
M20	R-STUDS-20260	R-STUDS-20260-88	R-STUDS-20260-A4	20	260	22	157	-
	R-STUDS-20300	-	R-STUDS-20300-A4	20	300	22	197	-
	R-STUDS-20350	-	R-STUDS-20350-A4	20	350	22	247	-

**Product information**

Size	Product Code			Anchor		Fixture		
	Steel class 5.8	Steel class 8.8	Steel grade A4	Diameter	Length	Hole diameter	Max. thickness $t_{fix}$ for:	
				d	L	$d_f$	$h_{nom,min}$	$h_{nom,max}$
[mm]	[mm]	[mm]	[mm]	[mm]	[mm]	[mm]	[mm]	
M24	R-STUDS-24300	R-STUDS-24300-88	R-STUDS-24300-A4	24	300	26	176	-
M30	R-STUDS-30380	R-STUDS-30380-88	R-STUDS-30380-A4	30	380	32	226	-

**Installation data**

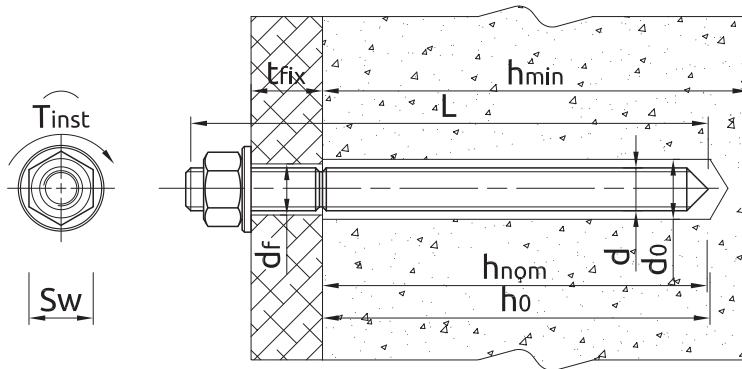

**R-STUDS**

Size	M8	M10	M12	M16	M20	M24	M30		
Thread diameter	d	[mm]	8	10	12	16	20	24	30
Hole diameter in substrate	$d_0$	[mm]	10	12	14	18	24	28	35
Hole diameter in fixture	$d_f$	[mm]	9	12	14	18	22	26	32
Min. hole depth in substrate	$h_0$	[mm]	$h_{nom} + 5$	$h_{nom} + 5$	$h_{nom} + 5$	$h_{nom} + 5$	$h_{nom} + 5$	$h_{nom} + 5$	$h_{nom} + 5$
Min. substrate thickness	$h_{min}$	[mm]	$h_{nom} + 30$ $\geq 100$	$h_{nom} + 30$ $\geq 100$	$h_{nom} + 30$ $\geq 100$	$h_{nom} + 2d_0$	$h_{nom} + 2d_0$	$h_{nom} + 2d_0$	$h_{nom} + 2d_0$
Installation torque	$T_{inst}$	[Nm]	10	20	40	80	120	160	200
Min. spacing	$s_{min}$	[mm]	40	40	40	40	40	50	60
Min. edge distance	$c_{min}$	[mm]	40	40	40	40	40	50	60
<b>MINIMUM EMBEDMENT DEPTH</b>									
Min. installation depth	$h_{nom,min}$	[mm]	60	60	60	60	80	96	120
<b>MAXIMUM EMBEDMENT DEPTH</b>									
Min. installation depth	$h_{nom,max}$	[mm]	160	200	240	320	400	480	600

**Minimum working and curing time**

**R-KER-II**

Resin temperature	Concrete temperature	Curing time*	Working time
[°C]	[°C]	[min]	[min]
5	0	3 h	30
5	5	90	15
10	10	60	8
15	15	60	5
20	20	45	2.5
25	25	45	2
25	30	45	2
25	35	30	1.5
25	40	30	1.5

\*For wet concrete the curing time must be doubled

## Installation data

R-KER-II S

Resin temperature	Concrete temperature	Curing time*	Working time
[°C]	[°C]	[min]	[min]
5	5	12 h	40
10	10	8 h	20
15	15	6 h	15
20	20	4 h	10
25	25	3 h	9.5
25	30	2 h	7
25	35	2 h	6.5
25	40	1.5 h	6.5

\*For wet concrete the curing time must be doubled

R-KER-II W

Resin temperature	Concrete temperature	Curing time*	Working time
[°C]	[°C]	[min]	[min]
5	0	2 h	14
5	5	60	9
10	10	45	5.5
15	15	30	3
20	20	15	2
25	25	10	1.5
25	30	10	1.5
25	35	5	1
25	40	5	1

\*For wet concrete the curing time must be doubled

## Mechanical properties

Size			M8	M10	M12	M16	M20	M24	M30
<b>R-STUDS Metric Threaded Rods - Steel Class 5.8</b>									
Nominal ultimate tensile strength - tension	$f_{uk}$	[N/mm <sup>2</sup> ]	500	500	500	500	500	500	500
Nominal yield strength - tension	$f_{yk}$	[N/mm <sup>2</sup> ]	400	400	400	400	400	400	400
Cross sectional area - tension	$A_s$	[mm <sup>2</sup> ]	37	58	84	157	245	353	560
Elastic section modulus	$W_{el}$	[mm <sup>3</sup> ]	31	62	109	278	541	935	1868
Characteristic bending resistance	$M^0_{Rk,s}$	[Nm]	19	37	65	166	324	561	1124
Design bending resistance	M	[Nm]	15	30	52	133	259	449	899
Allowable bending resistance	$M_{rec}$	[Nm]	11	21	37	95	185	321	642
<b>R-STUDS Metric Threaded Rods - Steel Class 8.8</b>									
Nominal ultimate tensile strength - tension	$f_{uk}$	[N/mm <sup>2</sup> ]	800	800	800	800	800	800	800
Nominal yield strength - tension	$f_{yk}$	[N/mm <sup>2</sup> ]	640	640	640	640	640	640	640
Cross sectional area - tension	$A_s$	[mm <sup>2</sup> ]	37	58	84	157	245	353	560
Elastic section modulus	$W_{el}$	[mm <sup>3</sup> ]	31	62	109	278	541	935	1868
Characteristic bending resistance	$M^0_{Rk,s}$	[Nm]	30	60	105	266	519	898	1799
Design bending resistance	M	[Nm]	24	48	84	213	416	718	1439
Allowable bending resistance	$M_{rec}$	[Nm]	17	34	60	152	297	513	1028

## Mechanical properties

Size			M8	M10	M12	M16	M20	M24	M30
<b>R-STUDS Metric Threaded Rods - A4</b>									
Nominal ultimate tensile strength - tension	$f_{uk}$	[N/mm <sup>2</sup> ]	700	700	700	700	700	700	700
Nominal yield strength - tension	$f_{yk}$	[N/mm <sup>2</sup> ]	450	450	450	450	450	450	450
Cross sectional area - tension	$A_s$	[mm <sup>2</sup> ]	37	58	84	157	245	353	560
Elastic section modulus	$W_{el}$	[mm <sup>3</sup> ]	31	62	109	278	541	935	1868
Characteristic bending resistance	$M^0_{Rk,s}$	[Nm]	26	52	92	233	454	786	1574
Design bending resistance	M	[Nm]	17	34	59	149	291	504	1009
Allowable bending resistance	$M_{rec}$	[Nm]	12	24	42	107	208	360	721

## Basic performance data

R-STUDS

Performance data for single anchor without influence of edge distance and spacing - ETAG 001

Size			M8	M10	M12	M16	M20	M24	M30	M8	M10	M12	M16	M20	M24	M30
Substrate	Non-cracked concrete						Cracked concrete									
<b>MEAN ULTIMATE LOAD</b>																
TENSION LOAD $N_{Ru,m}$																
R-STUDS METRIC THREADED RODS - STEEL CLASS 5.8																
Minimum embedment depth	[kN]	22.0	28.2	28.2	28.2	43.4	57.0	79.7	20.1	20.1	20.1	20.1	30.9	40.6	56.8	
Maximum embedment depth	[kN]	22.0	34.8	50.6	94.2	147.0	211.7	335.9	22.0	34.8	50.6	94.2	147.0	211.7	335.9	
R-STUDS METRIC THREADED RODS - STEEL CLASS 8.8																
Minimum embedment depth	[kN]	28.2	28.2	28.2	28.2	43.4	57.0	79.7	20.1	20.1	20.1	20.1	30.9	40.6	56.8	
Maximum embedment depth	[kN]	32.9	52.2	75.9	141.3	220.5	317.5	503.8	32.9	52.2	75.9	141.3	220.5	317.5	503.8	
R-STUDS METRIC THREADED RODS - A4																
Minimum embedment depth	[kN]	28.2	28.2	28.2	28.2	43.4	57.0	79.7	20.1	20.1	20.1	20.1	30.9	40.6	56.8	
Maximum embedment depth	[kN]	28.9	45.8	66.6	124.0	193.6	278.7	442.2	28.9	45.8	66.6	124.0	193.6	278.7	442.2	
SHEAR LOAD $V_{Ru,m}$																
R-STUDS METRIC THREADED RODS - STEEL CLASS 5.8																
Minimum embedment depth	[kN]	11.0	17.4	25.3	47.1	73.5	105.8	167.9	11.0	17.4	25.3	47.1	73.5	105.8	135.7	
Maximum embedment depth	[kN]	11.0	17.4	25.3	47.1	73.5	105.8	167.9	11.0	17.4	25.3	47.1	73.5	105.8	167.9	
R-STUDS METRIC THREADED RODS - STEEL CLASS 8.8																
Minimum embedment depth	[kN]	16.5	26.1	37.9	70.7	110.3	158.8	194.3	16.5	26.1	37.9	64.3	84.8	114.1	115.0	
Maximum embedment depth	[kN]	16.5	26.1	37.9	70.7	110.3	158.8	240.4	16.5	26.1	37.9	70.7	110.3	158.8	226.9	
R-STUDS METRIC THREADED RODS - A4																
Minimum embedment depth	[kN]	14.5	22.9	33.3	62.0	96.8	139.4	221.1	14.5	22.9	33.3	62.0	85.3	114.3	170.7	
Maximum embedment depth	[kN]	14.5	22.9	33.3	62.0	96.8	139.4	221.1	14.5	22.9	33.3	62.0	96.8	139.4	221.1	

### Basic performance data

Size		M8	M10	M12	M16	M20	M24	M30	M8	M10	M12	M16	M20	M24	M30
<b>CHARACTERISTIC LOAD</b>															
TENSION LOAD $N_{Rk}$															
R-STUDS METRIC THREADED RODS - STEEL CLASS 5.8															
Minimum embedment depth	[kN]	18.0	23.5	23.5	23.5	36.1	47.5	66.4	15.1	16.7	16.7	16.7	25.8	33.9	47.3
Maximum embedment depth	[kN]	18.0	29.0	42.0	78.0	122.0	176.0	280.0	18.0	29.0	42.0	78.0	122.0	176.0	280.0
R-STUDS METRIC THREADED RODS - STEEL CLASS 8.8															
Minimum embedment depth	[kN]	23.5	23.5	23.5	23.5	36.1	47.5	66.4	15.1	16.7	16.7	16.7	25.8	33.9	47.3
Maximum embedment depth	[kN]	29.0	46.0	67.0	126.0	196.0	282.0	448.0	29.0	46.0	67.0	126.0	188.5	253.3	282.7
R-STUDS METRIC THREADED RODS - A4															
Minimum embedment depth	[kN]	23.5	23.5	23.5	23.5	36.1	47.5	66.4	15.1	16.7	16.7	16.7	25.8	33.9	47.3
Maximum embedment depth	[kN]	26.0	41.0	59.0	110.0	171.0	247.0	392.0	26.0	41.0	59.0	110.0	171.0	247.0	282.7
SHEAR LOAD $V_{Rk}$															
R-STUDS METRIC THREADED RODS - STEEL CLASS 5.8															
Minimum embedment depth	[kN]	9.00	14.0	21.0	39.0	61.0	88.0	132.8	9.00	14.0	21.0	33.5	51.5	67.7	94.7
Maximum embedment depth	[kN]	9.00	14.0	21.0	39.0	61.0	88.0	140.0	9.00	14.0	21.0	39.0	61.0	88.0	140.0
R-STUDS METRIC THREADED RODS - STEEL CLASS 8.8															
Minimum embedment depth	[kN]	15.0	23.0	34.0	46.9	72.3	95.0	132.8	15.0	23.0	33.5	33.5	51.5	67.7	94.7
Maximum embedment depth	[kN]	15.0	23.0	34.0	63.0	98.0	141.0	224.0	15.0	23.0	34.0	63.0	98.0	141.0	224.0
R-STUDS METRIC THREADED RODS - A4															
Minimum embedment depth	[kN]	13.0	20.5	29.0	46.9	72.3	95.0	132.8	13.0	20.0	29.0	33.5	51.5	67.7	94.7
Maximum embedment depth	[kN]	13.0	20.5	29.0	55.0	86.0	124.0	196.0	13.0	20.0	29.0	55.0	86.0	124.0	196.0
<b>DESIGN LOAD</b>															
TENSION LOAD $N_{Rd}$															
R-STUDS METRIC THREADED RODS - STEEL CLASS 5.8															
Minimum embedment depth	[kN]	12.0	15.7	15.7	15.7	24.1	31.7	44.3	10.1	11.2	11.2	11.2	17.2	22.6	31.6
Maximum embedment depth	[kN]	12.0	19.3	28.0	52.0	81.3	117.3	186.7	12.0	19.3	28.0	52.0	81.3	117.3	186.7
R-STUDS METRIC THREADED RODS - STEEL CLASS 8.8															
Minimum embedment depth	[kN]	15.7	15.7	15.7	15.7	24.1	31.7	44.3	10.1	11.2	11.2	11.2	17.2	22.6	31.6
Maximum embedment depth	[kN]	19.3	30.7	44.7	84.0	130.7	188.0	298.7	19.3	30.7	44.7	84.0	125.7	168.9	188.5
R-STUDS METRIC THREADED RODS - A4															
Minimum embedment depth	[kN]	13.9	15.7	15.7	15.7	24.1	31.7	44.3	10.1	11.2	11.2	11.2	17.2	22.6	31.6
Maximum embedment depth	[kN]	13.9	21.9	31.6	58.8	91.4	132.1	209.6	13.9	21.9	31.6	58.8	91.4	132.1	188.5
SHEAR LOAD $V_{Rd}$															
R-STUDS METRIC THREADED RODS - STEEL CLASS 5.8															
Minimum embedment depth	[kN]	7.20	11.2	16.8	31.2	48.2	63.3	88.5	7.20	11.2	16.8	22.3	34.4	45.2	63.1
Maximum embedment depth	[kN]	7.20	11.2	16.8	31.2	48.8	70.4	112.0	7.20	11.2	16.8	31.2	48.8	70.4	112.0
R-STUDS METRIC THREADED RODS - STEEL CLASS 8.8															
Minimum embedment depth	[kN]	12.0	18.4	27.2	31.3	48.2	63.3	88.5	12.0	18.4	22.3	22.3	34.4	45.2	63.1
Maximum embedment depth	[kN]	12.0	18.4	27.2	50.4	78.4	112.8	179.2	12.0	18.4	27.2	50.4	78.4	112.8	179.2
R-STUDS METRIC THREADED RODS - A4															
Minimum embedment depth	[kN]	8.33	13.1	18.6	31.3	48.2	63.3	88.5	8.33	12.8	18.6	22.3	34.4	45.2	63.1
Maximum embedment depth	[kN]	8.33	13.1	18.6	35.3	55.1	79.5	125.6	8.33	12.8	18.6	35.3	55.1	79.5	125.6

### Basic performance data

Size		M8	M10	M12	M16	M20	M24	M30	M8	M10	M12	M16	M20	M24	M30
<b>RECOMMENDED LOAD</b>															
TENSION LOAD $N_{rec}$															
R-STUDS METRIC THREADED RODS - STEEL CLASS 5.8															
Minimum embedment depth	[kN]	8.57	11.2	11.2	11.2	17.2	22.6	31.6	7.18	7.97	7.97	7.97	12.3	16.1	22.5
Maximum embedment depth	[kN]	8.57	13.8	20.0	37.1	58.1	83.8	133.3	8.57	13.8	20.0	37.1	58.1	83.8	133.3
R-STUDS METRIC THREADED RODS - STEEL CLASS 8.8															
Minimum embedment depth	[kN]	11.2	11.2	11.2	11.2	17.2	22.6	31.6	7.18	7.97	7.97	7.97	12.3	16.1	22.5
Maximum embedment depth	[kN]	13.8	21.9	31.9	60.0	93.3	134.3	213.3	13.8	21.9	31.9	60.0	89.8	120.6	134.6
R-STUDS METRIC THREADED RODS - A4															
Minimum embedment depth	[kN]	9.93	11.2	11.2	11.2	17.2	22.6	31.6	7.18	7.97	7.97	7.97	12.3	16.1	22.5
Maximum embedment depth	[kN]	9.93	15.7	22.5	42.0	65.3	94.4	149.7	9.93	15.7	22.5	42.0	65.3	94.4	134.6
SHEAR LOAD $V_{rec}$															
R-STUDS METRIC THREADED RODS - STEEL CLASS 5.8															
Minimum embedment depth	[kN]	5.14	8.00	12.0	22.3	34.4	45.2	63.2	5.14	8.00	12.0	15.9	24.5	32.3	45.1
Maximum embedment depth	[kN]	5.14	8.00	12.0	22.3	34.9	50.3	80.0	5.14	8.00	12.0	22.3	34.9	50.3	80.0
R-STUDS METRIC THREADED RODS - STEEL CLASS 8.8															
Minimum embedment depth	[kN]	8.57	13.1	19.4	22.4	31.4	45.2	63.2	8.57	13.1	15.9	15.9	24.5	32.3	45.1
Maximum embedment depth	[kN]	8.57	13.1	19.4	36.0	56.0	80.6	128.0	8.57	13.1	19.4	36.0	56.0	80.6	128.0
R-STUDS METRIC THREADED RODS - A4															
Minimum embedment depth	[kN]	5.95	9.39	13.3	22.4	34.4	45.2	53.2	5.95	9.16	13.3	15.9	24.5	32.3	45.1
Maximum embedment depth	[kN]	5.95	9.39	13.3	25.2	39.4	56.8	89.7	5.95	9.16	13.3	25.2	39.4	56.8	89.7

## Design performance data

R-STUDS

Size			M8	M10	M12	M16	M20	M24	M30
<b>TENSION LOAD</b>									
<b>STEEL FAILURE; STEEL CLASS S.8</b>									
Characteristic resistance	$N_{Rk,s}$	[kN]	18.00	29.00	42.00	78.00	122.00	176.00	280.00
Partial safety factor	$\gamma_{Ms}$	-	1.50	1.50	1.50	1.50	1.50	1.50	1.50
<b>STEEL FAILURE; STEEL CLASS 8.8</b>									
Characteristic resistance	$N_{Rk,s}$	[kN]	29.00	46.00	67.00	126.00	196.00	282.00	448.00
Partial safety factor	$\gamma_{Ms}$	-	1.50	1.50	1.50	1.50	1.50	1.50	1.50
<b>STEEL FAILURE; STEEL GRADE A4-70</b>									
Characteristic resistance	$N_{Rk,s}$	[kN]	26.00	41.00	59.00	110.00	171.00	247.00	392.00
Partial safety factor	$\gamma_{Ms}$	-	1.87	1.87	1.87	1.87	1.87	1.87	1.87
<b>COMBINED PULL-OUT AND CONCRETE CONE FAILURE; NON-CRACKED CONCRETE, C20/25 (40°C/24°C)</b>									
Characteristic bond resistance	$T_{Rk}$	[N/mm <sup>2</sup> ]	16.00	15.00	15.00	13.00	10.00	10.00	8.00
<b>COMBINED PULL-OUT AND CONCRETE CONE FAILURE; NON-CRACKED CONCRETE, C20/25 (80°C/50°C)</b>									
Characteristic bond resistance	$T_{Rk}$	[N/mm <sup>2</sup> ]	16.00	15.00	15.00	13.00	10.00	10.00	8.00
<b>COMBINED PULL-OUT AND CONCRETE CONE FAILURE; NON-CRACKED CONCRETE, C20/25 (120°C/80°C)</b>									
Characteristic bond resistance	$T_{Rk}$	[N/mm <sup>2</sup> ]	8.50	8.00	8.00	7.00	5.50	5.50	4.50
<b>COMBINED PULL-OUT AND CONCRETE CONE FAILURE; CRACKED CONCRETE, C20/25 (40°C/24°C)</b>									
Characteristic bond resistance	$T_{Rk}$	[N/mm <sup>2</sup> ]	10.00	11.00	11.00	9.50	7.50	7.00	5.00
<b>COMBINED PULL-OUT AND CONCRETE CONE FAILURE; CRACKED CONCRETE, C20/25 (80°C/50°C)</b>									
Characteristic bond resistance	$T_{Rk}$	[N/mm <sup>2</sup> ]	10.00	11.00	11.00	9.50	7.50	7.00	5.00
<b>COMBINED PULL-OUT AND CONCRETE CONE FAILURE; CRACKED CONCRETE, C20/25 (120°C/80°C)</b>									
Characteristic bond resistance	$T_{Rk}$	[N/mm <sup>2</sup> ]	5.00	6.00	6.00	5.00	4.00	4.00	3.00
<b>COMBINED PULL-OUT AND CONCRETE CONE FAILURE</b>									
Installation safety factor	$\gamma_2$	-	1.00	1.00	1.00	1.00	1.00	1.00	1.00
Increasing factors for $N_{Rd,p}$ - C30/37	$\psi_c$	-	1.05	1.04	1.04	1.04	1.04	1.04	1.04
Increasing factors for $N_{Rd,p}$ - C40/50	$\psi_c$	-	1.07	1.07	1.07	1.07	1.07	1.07	1.07
Increasing factors for $N_{Rd,p}$ - C50/60	$\psi_c$	-	1.09	1.09	1.09	1.09	1.09	1.09	1.09
<b>CONCRETE CONE FAILURE</b>									
Installation safety factor	$\gamma_2$	-	1.00	1.00	1.00	1.00	1.00	1.00	1.00
Factor for cracked concrete	k	-	7.20	7.20	7.20	7.20	7.20	7.20	7.20
Factor for cracked concrete	$k_{cr,N}$	-	7.70	7.70	7.70	7.70	7.70	7.70	7.70
Factor for non-cracked concrete	k	-	10.10	10.10	10.10	10.10	10.10	10.10	10.10
Factor for non-cracked concrete	$k_{ucr,N}$	-	11.00	11.00	11.00	11.00	11.00	11.00	11.00
Edge distance	$c_{cr,N}$	[mm]	1.5* $h_{ef}$	1.5* $h_{ef}$	1.5* $h_{ef}$	1.5* $h_{ef}$	1.5* $h_{ef}$	1.5* $h_{ef}$	1.5* $h_{ef}$
Spacing	$s_{cr,N}$	[mm]	3.0* $h_{ef}$	3.0* $h_{ef}$	3.0* $h_{ef}$	3.0* $h_{ef}$	3.0* $h_{ef}$	3.0* $h_{ef}$	3.0* $h_{ef}$
<b>CONCRETE SPLITTING FAILURE</b>									
Installation safety factor	$\gamma_2$	-	1.00	1.00	1.00	1.00	1.00	1.00	1.00



## Design performance data

Size			M8	M10	M12	M16	M20	M24	M30
<b>SHEAR LOAD</b>									
<b>STEEL FAILURE; STEEL CLASS 5.8</b>									
Characteristic resistance without lever arm	$V_{Rk,s}$	[kN]	9.00	14.00	21.00	39.00	61.00	88.00	140.00
Ductility factor	$k_7$	-	0.80	0.80	0.80	0.80	0.80	0.80	0.80
Characteristic resistance with lever arm	$M_{Rk,s}$	[Nm]	19.00	37.00	65.00	166.00	324.00	561.00	1124.00
Partial safety factor	$\gamma_{Ms}$	-	1.25	1.25	1.25	1.25	1.25	1.25	1.25
<b>STEEL FAILURE; STEEL CLASS 8.8</b>									
Characteristic resistance without lever arm	$V_{Rk,s}$	[kN]	15.00	23.00	34.00	63.00	98.00	141.00	224.00
Ductility factor	$k_7$	-	0.80	0.80	0.80	0.80	0.80	0.80	0.80
Characteristic resistance with lever arm	$M_{Rk,s}$	[Nm]	30.00	60.00	105.00	266.00	519.00	898.00	1799.00
Partial safety factor	$\gamma_{Ms}$	-	1.25	1.25	1.25	1.25	1.25	1.25	1.25
<b>STEEL FAILURE; STEEL GRADE A4-70</b>									
Characteristic resistance without lever arm	$V_{Rk,s}$	[kN]	13.00	20.00	29.00	55.00	86.00	124.00	196.00
Ductility factor	$k_7$	-	0.80	0.80	0.80	0.80	0.80	0.80	0.80
Characteristic resistance with lever arm	$M_{Rk,s}$	[Nm]	26.00	52.00	92.00	233.00	454.00	786.00	1574.00
Partial safety factor	$\gamma_{Ms}$	-	1.56	1.56	1.56	1.56	1.56	1.56	1.56
<b>CONCRETE PRY-OUT FAILURE</b>									
Factor	$k$	-	2.00	2.00	2.00	2.00	2.00	2.00	2.00
Installation safety factor	$\gamma_2$	-	1.00	1.00	1.00	1.00	1.00	1.00	1.00
<b>CONCRETE EDGE FAILURE</b>									
Anchor diameter	$d_{nom}$	[mm]	8.00	10.00	12.00	16.00	20.00	24.00	30.00
Effective length of anchor	$\ell_f$	[mm]	min ( $h_{ef}; 8d_{nom}$ )	min ( $h_{ef}; 8d_{nom}$ )	min ( $h_{ef}; 8d_{nom}$ )	min ( $h_{ef}; 8d_{nom}$ )	min ( $h_{ef}; 8d_{nom}$ )	min ( $h_{ef}; 8d_{nom}$ )	min ( $h_{ef}; 8d_{nom}$ )
Installation safety factor	$\gamma_2$	-	1.00	1.00	1.00	1.00	1.00	1.00	1.00

Combined pull-out and concrete cone failure (TR 029, p.5.2.2.3. acc. to formula 5.2a -  $N_{Rk,p}^0 = n \cdot d \cdot h_{ef} \cdot \tau_{Rk}$ ).

Concrete cone failure (TR 029, p.5.2.2.4. acc. to formula 5.3a -  $N_{Rk,c}^0 = k_1 \cdot f_{ck,cube}^{0.5} \cdot h_{ef}^{1.5}$ ).

$h_{ef} = h_{nom}$

Allowable values for resistance in case of Seismic performance category C1

Size			M8	M10	M12	M16	M20	M24	M30
<b>TENSION LOAD</b>									
<b>STEEL FAILURE; STEEL CLASS 5.8</b>									
Characteristic resistance	$N_{Rk,s}$	[kN]	18.00	29.00	42.00	78.00	122.00	176.00	280.00
Partial safety factor	$\gamma_{Ms,seisC1}$	-	1.50	1.50	1.50	1.50	1.50	1.50	1.50
<b>STEEL FAILURE; STEEL CLASS 8.8</b>									
Characteristic resistance	$N_{Rk,s}$	[kN]	29.00	46.00	67.00	126.00	196.00	282.00	448.00
Partial safety factor	$\gamma_{Ms,seisC1}$	-	1.50	1.50	1.50	1.50	1.50	1.50	1.50
<b>STEEL FAILURE; STEEL GRADE A4-70</b>									
Characteristic resistance	$N_{Rk,s}$	[kN]	26.00	41.00	59.00	110.00	171.00	247.00	392.00
Partial safety factor	$\gamma_{Ms,seisC1}$	-	1.87	1.87	1.87	1.87	1.87	1.87	1.87
<b>COMBINED PULL-OUT AND CONCRETE CONE FAILURE; CRACKED CONCRETE, C20/25 (40°C/24°C)</b>									
Characteristic bond resistance	$T_{Rk}$	[N/mm <sup>2</sup> ]	8.00	10.00	10.00	9.50	7.50	7.00	4.00
<b>COMBINED PULL-OUT AND CONCRETE CONE FAILURE; CRACKED CONCRETE, C20/25 (80°C/50°C)</b>									
Characteristic bond resistance	$T_{Rk}$	[N/mm <sup>2</sup> ]	8.00	10.00	10.00	9.50	7.50	7.00	4.00
<b>COMBINED PULL-OUT AND CONCRETE CONE FAILURE; CRACKED CONCRETE, C20/25 (120°C/80°C)</b>									
Characteristic bond resistance	$T_{Rk}$	[N/mm <sup>2</sup> ]	4.50	5.00	6.00	5.00	4.00	4.00	2.00
<b>PULL-OUT FAILURE</b>									
Partial safety factor	$\gamma_{Mp,seisC1}$	-	1.50	1.50	1.50	1.50	1.50	1.50	1.50

## Design performance data

Size	M8	M10	M12	M16	M20	M24	M30		
<b>SHEAR LOAD</b>									
<b>STEEL FAILURE; STEEL CLASS 5.8</b>									
Characteristic resistance without lever arm	$V_{Rk,s}$	[kN]	6.30	10.10	14.70	27.30	42.70	61.60	98.00
Partial safety factor	$V_{MsV,seisC1}$	-	1.25	1.25	1.25	1.25	1.25	1.25	1.25
<b>STEEL FAILURE; STEEL CLASS 8.8</b>									
Characteristic resistance without lever arm	$V_{Rk,s}$	[kN]	10.20	16.10	23.50	44.10	68.60	98.70	156.80
Partial safety factor	$V_{MsV,seisC1}$	-	1.25	1.25	1.25	1.25	1.25	1.25	1.25
<b>STEEL FAILURE; STEEL GRADE A4-70</b>									
Characteristic resistance without lever arm	$V_{Rk,s}$	[kN]	9.10	14.40	20.70	38.50	59.90	86.50	137.40
Partial safety factor	$V_{MsV,seisC1}$	-	1.56	1.56	1.56	1.56	1.56	1.56	1.56

## Product commercial data

Size	Product Code	Volume [ml]	Quantity [pcs]			Weight [kg]			Bar Codes
			Box	Outer	Pallet	Box	Outer	Pallet	
M16	R-KER-II-300 <sup>1)</sup>	300	10	10	840	5.9	5.9	525.6	5906675293738
	R-KER-II-345 <sup>1)</sup>	345	10	10	840	7.6	7.6	668.4	5906675395203
	R-KER-II-400 <sup>1)</sup>	400	10	10	560	8.2	8.2	489.2	5906675392103
	R-KER-II-300-S <sup>1)</sup>	300	10	10	840	5.9	5.9	525.6	5906675432045
	R-KER-II-400-S <sup>1)</sup>	400	10	10	560	8.2	8.2	489.2	5906675432076
	R-KER-II-300-W <sup>1)</sup>	300	10	10	840	5.9	5.9	525.6	5906675432038
	R-KER-II-345-W <sup>1)</sup>	345	10	10	840	7.6	7.6	668.4	5906675432052
	R-KER-II-400-W <sup>1)</sup>	400	10	10	560	8.2	8.2	489.2	5906675432069

1) ETA-17/0594