

R-SPL-II-P SafetyPlus II - Bolt Projecting

High performance mechanical anchor - loose bolt option

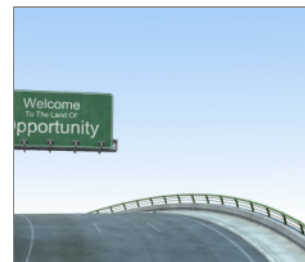
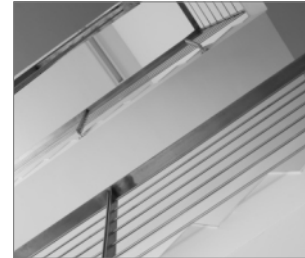

Approvals and Reports

- ETA-14/0345



Product information

Features and benefits

- Mechanical anchor for highest tension and shear loads
- Seismic category C2 for structural applications. Seismic category C1 for non-structural use in areas with low seismic risk.
- For usage with required fire resistance
- ETA Option 1 for cracked and non-cracked concrete.
- Antirotation brush to prevent rotation during installation.
- Anchor's construction allows easy through-installation (drilling and installation through fixed material)
- Three types of tips (nut, flat or tapered bolt) allow simple fitment for installed element
- 8.8 grade steel material of anchor provides high durability

Applications

- Structural steelwork
- Masonry support
- Cladding restraint
- Road Signs
- Heavy machinery
- Racking systems
- Industrial doors
- Safety barriers

Base materials

Approved for use in:

- Cracked concrete C20/25-C50/60
- Non-cracked concrete C20/25-C50/60
- Unreinforced concrete
- Reinforced concrete

Also suitable for use in:

- Natural Stone (after site testing)

Installation guide



1. Drill a hole of required diameter and depth
2. Clear the hole of drilling dust and debris (using blowpump or equivalent method)
3. Insert anchor through fixture into hole and tap until required installation depth is achieved
4. Tighten to the recommended torque

Product information

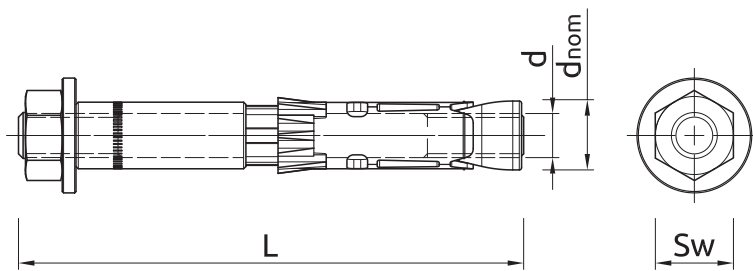

Size	Product Code	Anchor			Fixture	
		Thread size	External diameter	Length	Max. thickness	Hole diameter
		d [mm]	d _{nom} [mm]	L [mm]	t _{fix} [mm]	d _f [mm]
M6	R-SPL-II-06110/50P	6	10	110	50	12
M8	R-SPL-II-08090/20P	8	12	90	20	14
M10	R-SPL-II-10100/20P	10	15	100	20	17
M12	R-SPL-II-12125/25P	12	18	125	25	20
	R-SPL-II-12150/50P	12	18	150	50	20
M16	R-SPL-II-16125/10P	16	24	125	10	26

Installation data

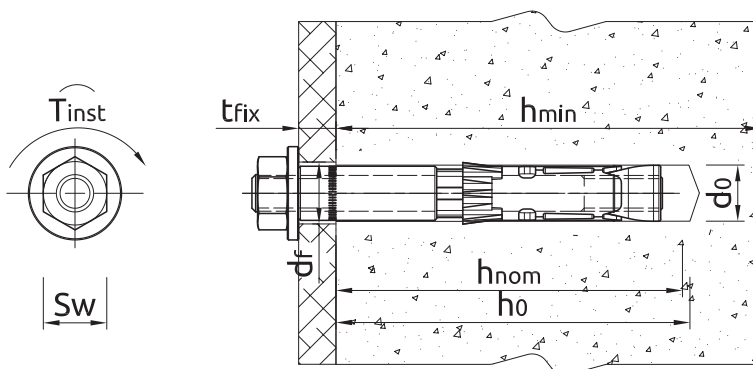

Size		M6	M8	M10	M12	M16
Thread diameter	d [mm]	6	8	10	12	16
Hole diameter in substrate	d _o [mm]	10	12	15	18	24
Hole diameter in fixture	d _f [mm]	12	14	17	20	26
Installation torque	T _{inst} [Nm]	10	20	45	80	150
Wrench size	Sw [mm]	10	13	17	19	24
Min. hole depth in substrate	h _o [mm]	75	85	95	115	130
Min. installation depth	h _{nom} [mm]	60	70	80	100	115
Min. substrate thickness	h _{min} [mm]	100	120	140	180	200
Min. spacing	s _{min} [mm]	50	60	70	80	100
Min. edge distance	c _{min} [mm]	50	60	70	80	100

Mechanical properties

Size		M6	M8	M10	M12	M16
Nominal ultimate tensile strength - tension	f _{uk} [N/mm ²]	800	800	800	800	830
Nominal yield strength - tension	f _{yk} [N/mm ²]	640	640	640	640	660
Cross sectional area - tension	A _s [mm ²]	20.1	36.6	58	84.3	157
Elastic section modulus	W _{el} [mm ³]	21.2	50.3	98.2	169.7	402.1
Characteristic bending resistance	M ⁰ _{Rk,s} [Nm]	12	30	60	105	266
Design bending resistance	M [Nm]	9.6	24	48	84	214

Basic performance data

Performance data for single anchor without influence of edge distance and spacing - ETAG 001

Size		M6	M8	M10	M12	M16
NON-CRACKED CONCRETE						
Effective embedment depth h_{ef}	[mm]	49.00	59.00	67.00	88.00	99.00
CRACKED CONCRETE						
Effective embedment depth h_{ef}	[mm]	49.00	59.00	67.00	88.00	99.00
CHARACTERISTIC LOAD						
TENSION LOAD N_{Rk}						
NON-CRACKED CONCRETE	[kN]	16.00	22.90	27.70	41.70	49.70
CRACKED CONCRETE	[kN]	9.00	12.00	16.00	25.00	35.50
SHEAR LOAD V_{Rk}						
NON-CRACKED CONCRETE	[kN]	14.00	22.90	42.00	50.00	97.00
CRACKED CONCRETE	[kN]	12.30	16.30	39.50	50.00	70.90
DESIGN LOAD						
TENSION LOAD N_{Rd}						
NON-CRACKED CONCRETE	[kN]	10.70	15.30	18.50	27.80	33.20
CRACKED CONCRETE	[kN]	6.00	8.00	10.70	16.70	23.60
SHEAR LOAD V_{Rd}						
NON-CRACKED CONCRETE	[kN]	11.20	15.30	33.60	40.00	66.30
CRACKED CONCRETE	[kN]	8.23	10.88	26.30	39.60	47.30
RECOMMENDED LOAD						
TENSION LOAD N_{rec}						
NON-CRACKED CONCRETE	[kN]	7.62	10.90	13.20	19.90	23.70
CRACKED CONCRETE	[kN]	4.29	5.71	7.62	11.90	16.90
SHEAR LOAD V_{rec}						
NON-CRACKED CONCRETE	[kN]	8.00	10.90	24.00	28.60	47.40
CRACKED CONCRETE	[kN]	5.88	7.77	18.80	28.30	33.80

Design performance data

(-) failure is not decisive

Size			M6	M8	M10	M12	M16
Effective embedment depth	h_{ef}	[mm]	49.00	59.00	67.00	88.00	99.00
TENSION LOAD							
STEEL FAILURE							
Characteristic resistance	$N_{Rk,s}$	[kN]	16.00	29.00	46.00	67.00	126.00
Partial safety factor	γ_{Ms}	-	1.50	1.50	1.50	1.50	1.50
PULL-OUT FAILURE; NON-CRACKED CONCRETE C20/25							
Characteristic resistance	$N_{Rk,p}$	[kN]	-	-	-	-	-
PULL-OUT FAILURE; CRACKED CONCRETE C20/25							
Characteristic resistance	$N_{Rk,p}$	[kN]	9.00	12.00	16.00	25.00	-
PULL-OUT FAILURE							
Installation safety factor	γ_2	-	1.00	1.00	1.00	1.00	1.00
Increasing factors for $N_{Rd,p}$ - C30/37	ψ_c	-	1.22	1.22	1.22	1.22	1.22
Increasing factors for $N_{Rd,p}$ - C40/50	ψ_c	-	1.41	1.41	1.41	1.41	1.41
Increasing factors for $N_{Rd,p}$ - C50/60	ψ_c	-	1.55	1.55	1.55	1.55	1.55
CONCRETE CONE FAILURE							
Installation safety factor	γ_2	-	1.00	1.00	1.00	1.00	1.00
Factor for cracked concrete	k	-	7.20	7.20	7.20	7.20	7.20
Factor for cracked concrete	$k_{cr,N}$	-	7.70	7.70	7.70	7.70	7.70
Factor for non-cracked concrete	k	-	10.10	10.10	10.10	10.10	10.10
Factor for non-cracked concrete	$k_{ucr,N}$	-	11.00	11.00	11.00	11.00	11.00
Spacing	$s_{cr,N}$	[mm]	147.00	177.00	201.00	264.00	297.00
Edge distance	$c_{cr,N}$	[mm]	73.50	88.50	100.50	132.00	148.50
CONCRETE SPLITTING FAILURE							
Installation safety factor	γ_2	-	1.00	1.00	1.00	1.00	1.00
Spacing	$s_{cr,sp}$	[mm]	147.00	177.00	201.00	264.00	297.00
Edge distance	$c_{cr,sp}$	[mm]	73.50	88.50	100.50	132.00	148.50
SHEAR LOAD							
STEEL FAILURE							
Characteristic resistance without lever arm	$V_{Rk,s}$	[kN]	14.00	26.00	42.00	50.00	97.00
Ductility factor	k_7	-	1.00	1.00	1.00	1.00	1.00
Characteristic resistance with lever arm	$M_{Rk,s}$	[Nm]	12.00	30.00	60.00	105.00	266.00
Partial safety factor	γ_{Ms}	-	1.25	1.25	1.25	1.25	1.25
CONCRETE PRY-OUT FAILURE							
Factor	k	-	1.00	1.00	2.00	2.00	2.00
Installation safety factor	γ_2	-	1.00	1.00	1.00	1.00	1.00
CONCRETE EDGE FAILURE							
Effective length of anchor	ℓ_f	[mm]	49.00	59.00	67.00	88.00	99.00
Anchor diameter	d_{nom}	[mm]	10.00	12.00	15.00	18.00	24.00
Installation safety factor	γ_2	-	1.00	1.00	1.00	1.00	1.00

Design performance data

Characteristic Resistance under fire exposure in concrete C20/25 to C50/60

Size			M6	M8	M10	M12	M16
TENSION LOAD							
Spacing	S_{cr}	[mm]	196.00	236.00	268.00	352.00	396.00
Edge distance	c_{cr}	[mm]	98.00	118.00	134.00	176.00	198.00
R (for EI) = 30 min							
TENSION LOAD							
STEEL FAILURE							
Characteristic resistance	$N_{Rk,s}$	[kN]	0.20	0.37	0.87	1.69	3.14
PULL-OUT FAILURE							
Characteristic resistance	$N_{Rk,p}$	[kN]	2.25	3.00	4.00	6.25	8.88
SHEAR LOAD							
STEEL FAILURE							
Characteristic resistance without lever arm	$V_{Rk,s}$	[kN]	0.20	0.37	0.87	1.69	3.14
Characteristic resistance with lever arm	$M_{Rk,s}$	[kN]	0.15	0.37	1.12	2.62	6.66
R (for EI) = 60 min							
TENSION LOAD							
STEEL FAILURE							
Characteristic resistance	$N_{Rk,s}$	[kN]	0.18	0.33	0.75	1.26	2.36
PULL-OUT FAILURE							
Characteristic resistance	$N_{Rk,p}$	[kN]	2.25	3.00	4.00	6.25	8.88
SHEAR LOAD							
STEEL FAILURE							
Characteristic resistance without lever arm	$V_{Rk,s}$	[kN]	0.18	0.33	0.75	1.26	2.36
Characteristic resistance with lever arm	$M_{Rk,s}$	[kN]	0.14	0.34	0.97	1.96	5.00
R (for EI) = 90 min							
TENSION LOAD							
STEEL FAILURE							
Characteristic resistance	$N_{Rk,s}$	[kN]	0.14	0.26	0.58	1.10	2.04
PULL-OUT FAILURE							
Characteristic resistance	$N_{Rk,p}$	[kN]	2.25	3.00	4.00	6.25	8.88
SHEAR LOAD							
STEEL FAILURE							
Characteristic resistance without lever arm	$V_{Rk,s}$	[kN]	0.14	0.26	0.58	1.10	2.06
Characteristic resistance with lever arm	$M_{Rk,s}$	[kN]	0.11	0.26	0.75	1.70	4.33
R (for EI) = 120 min							
TENSION LOAD							
STEEL FAILURE							
Characteristic resistance	$N_{Rk,s}$	[kN]	0.10	0.18	0.46	0.84	1.57
PULL-OUT FAILURE							
Characteristic resistance	$N_{Rk,p}$	[kN]	1.80	2.40	3.20	5.00	7.10
SHEAR LOAD							
STEEL FAILURE							
Characteristic resistance without lever arm	$V_{Rk,s}$	[kN]	0.10	0.18	0.46	0.84	1.57
Characteristic resistance with lever arm	$M_{Rk,s}$	[kN]	0.08	0.19	0.60	1.31	3.33

Design performance data

Allowable values for resistance in case of Seismic performance category C1

Size			M6	M8	M10	M12	M16
Effective embedment depth	h_{ef}	[mm]	49.00	59.00	67.00	88.00	99.00
TENSION LOAD, STEEL FAILURE							
Characteristic resistance	$N_{Rk,s}$	[kN]	16.00	29.00	46.00	67.00	126.00
Partial safety factor	$\gamma_{MsN,seisC1}$	-	1.50				
TENSION LOAD, PULL-OUT FAILURE							
Characteristic resistance	$N_{Rk,p}$	[kN]	6.80	12.00	16.00	25.00	35.50
Partial safety factor	$\gamma_{Mp,seisC1}$	-	1.50				
SHEAR LOAD, STEEL FAILURE							
Characteristic resistance without lever arm	$V_{Rk,s}$	[kN]	9.80	13.00	20.00	48.50	
Partial safety factor	$\gamma_{MsV,seisC1}$	-	1.25				

Allowable values for resistance in case of Seismic performance category C2

Size			M6	M8	M10	M12	M16
Effective embedment depth	h_{ef}	[mm]	49.00	59.00	67.00	88.00	99.00
TENSION LOAD, STEEL FAILURE							
Characteristic resistance	$N_{Rk,s}$	[kN]	-	29.00	46.00	67.00	126.00
Partial safety factor	$\gamma_{MsN,seisC2}$	-	1.50				
TENSION LOAD, PULL-OUT FAILURE							
Characteristic resistance	$N_{Rk,p}$	[kN]	-	3.90	7.80	15.20	28.80
Partial safety factor	$\gamma_{Mp,seisC2}$	-	1.50				
SHEAR LOAD, STEEL FAILURE							
Characteristic resistance without lever arm	$V_{Rk,s}$	[kN]	-	10.20	17.00	43.00	
Partial safety factor	$\gamma_{MsV,seisC2}$	-	1.25				

Product commercial data

Size	Product Code	Anchor		Quantity [pcs]			Weight [kg]			Bar Codes
		Thread size [mm]	Length [mm]	Box	Outer	Pallet	Box	Outer	Pallet	
M6	R-SPL-II-06110/50P ¹⁾	6	110	50	300	7200	3.0	17.7	454.8	5010445007354
M8	R-SPL-II-08090/20P ¹⁾	8	90	25	200	4800	1.73	13.8	362.2	5010445007361
M10	R-SPL-II-10100/20P ¹⁾	10	100	20	160	3840	2.6	20.6	525.4	5010445007378
M12	R-SPL-II-12125/25P ¹⁾	12	125	20	20	3840	4.5	4.5	899.6	5010445007385
	R-SPL-II-12150/50P ¹⁾	12	150	20	20	2200	4.5	4.5	527.2	5906675375489
M16	R-SPL-II-16125/10P ¹⁾	16	125	10	60	1440	4.3	25.9	652.1	5010445007392

1) ETA-14/0345