

R-KEX II with Threaded Rods

Premium pure epoxy resin approved for use in cracked and non-cracked concrete



Approvals and Reports

• ETA-13/0455

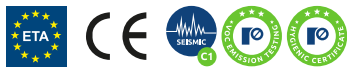

Product information

Features and benefits

- The strongest resin in the epoxy resin class
- Approved for use with threaded rods for use in cracked and non-cracked concrete (EAD 330499-00-0601)
- Suitable for use in dry and wet substrates including flooded holes (use category I1 & I2)
- Seismic category C1
- Installation direction D3 (downward and horizontal and upwards installation)
- Minimal shrinkage provides option of use in diamond-drilled holes and oversized holes
- Very high chemical resistance – suitable for applications exposed to influence of various agents (industrial or marine environment)
- Extended working time ensures easy installation of metal components (up to 30 min. in 20°C)
- For use in positive temperatures

Applications

- Safety barriers
- Formwork support systems
- Structural steelwork
- Street lamps
- Curtain walling
- Racking systems
- Balustrading
- Barriers
- Cladding restraints
- Masonry support
- Heavy machinery
- Platforms

Base materials

Approved for use in:

- Cracked concrete C20/25-C50/60
- Non-cracked concrete C20/25-C50/60

Installation guide

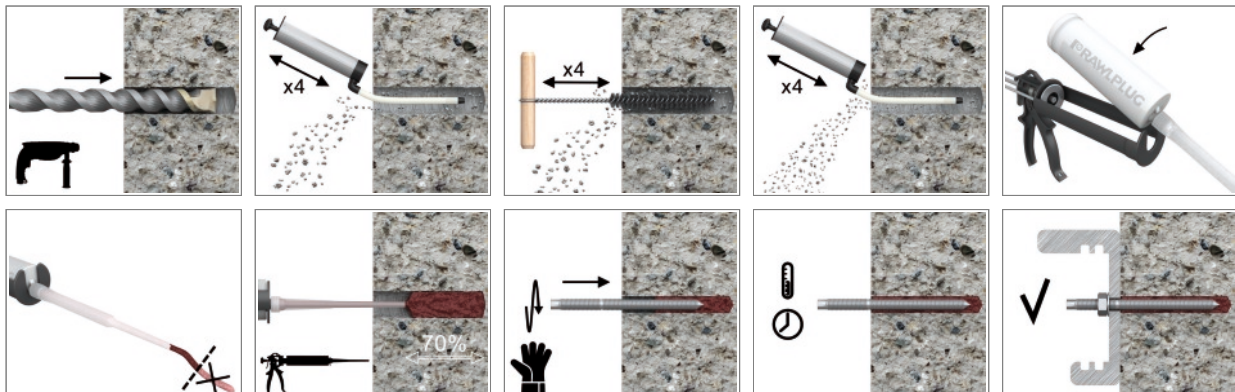

Product information

1. Drill hole to the required diameter and depth for stud size being used.
2. Clean the hole thoroughly with brush and hand pump at least four times before installation.
3. Insert cartridge into gun and attach nozzle.
4. Dispense to waste until even colour is obtained.
5. Insert the mixer nozzle to the bottom of the drill hole and inject resin, slowly withdrawing the nozzle as the hole is filled to 70% of its depth.
6. Immediately insert the stud, slowly and with slight twisting motion. Remove any excess resin around the hole before it sets and leave it undisturbed until the curing time elapses.
7. Attach fixture and tighten the nut to the required torque.

Size	Product Code	Resin	Description / Resin Type	Volume
				[ml]
M8	R-KEX-II-385	R-KEX II	Epoxy Resin	385
M30	R-KEX-II-600			600

Product Code	Resin	Description / Resin Type	Volume
			[ml]
R-KEX-II-385	R-KEX II	Epoxy Resin	385
R-KEX-II-600			600

R-STUDS

Size	Product Code			Anchor		Fixture		
	Steel class 5.8	Steel class 8.8	Steel grade A4	Diameter	Length	Hole diameter	Max. thickness t_{fix} for:	
				d	L	d_f	$h_{nom, min}$	$h_{nom, max}$
				[mm]	[mm]	[mm]	[mm]	[mm]
M8	R-STUDS-08110	R-STUDS-08110-88	R-STUDS-08110-A4	8	110	9	40	-
	R-STUDS-08160	-	R-STUDS-08160-A4	8	160	9	90	-
M10	R-STUDS-10130	R-STUDS-10130-88	R-STUDS-10130-A4	10	130	12	48	-
	R-STUDS-10170	-	R-STUDS-10170-A4	10	170	12	88	-
	R-STUDS-10190	-	R-STUDS-10190-A4	10	190	12	108	-
M12	R-STUDS-12160	R-STUDS-12160-88	R-STUDS-12160-A4	12	160	14	65	-
	R-STUDS-12190	-	R-STUDS-12190-A4	12	190	14	95	-
	R-STUDS-12220	-	R-STUDS-12220-A4	12	220	14	125	-
	R-STUDS-12260	-	R-STUDS-12260-A4	12	260	14	165	-
M16	R-STUDS-12300	-	R-STUDS-12300-A4	12	300	14	205	45
	R-STUDS-16190	R-STUDS-16190-88	R-STUDS-16190-A4	16	190	18	71	-
	R-STUDS-16220	R-STUDS-16220-88	R-STUDS-16220-A4	16	220	18	101	-
	R-STUDS-16260	-	R-STUDS-16260-A4	16	260	18	141	-
	R-STUDS-16300	-	R-STUDS-16300-A4	16	300	18	181	-
M20	R-STUDS-16380	-	R-STUDS-16380-A4	16	380	18	261	41
	R-STUDS-20260	R-STUDS-20260-88	R-STUDS-20260-A4	20	260	22	117	-
	R-STUDS-20300	-	R-STUDS-20300-A4	20	300	22	157	-
	R-STUDS-20350	-	R-STUDS-20350-A4	20	350	22	207	-
M24	R-STUDS-24300	R-STUDS-24300-88	R-STUDS-24300-A4	24	300	26	132	-
M30	R-STUDS-30380	R-STUDS-30380-88	R-STUDS-30380-A4	30	380	32	181	-

Installation data

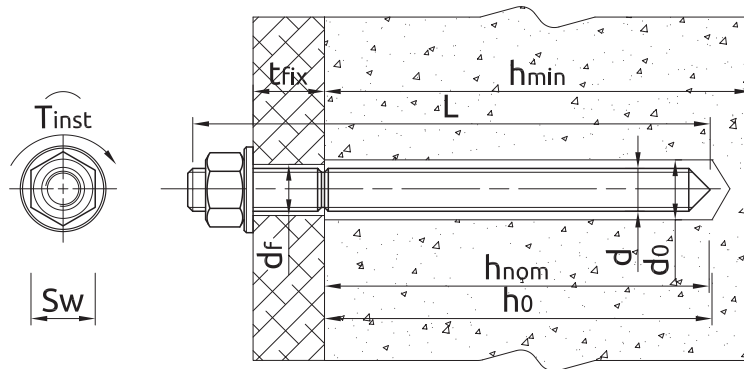

R-STUDS

Size	M8	M10	M12	M16	M20	M24	M30		
Thread diameter	d	[mm]	8	10	12	16	20	24	30
Hole diameter in substrate	d ₀	[mm]	10	12	14	18	24	28	35
Hole diameter in fixture	d _f	[mm]	9	12	14	18	22	26	32
Min. hole depth in substrate	h ₀	[mm]	h _{nom} + 5	h _{nom} + 5	h _{nom} + 5	h _{nom} + 5	h _{nom} + 5	h _{nom} + 5	h _{nom} + 5
Min. substrate thickness	h _{min}	[mm]	h _{nom} + 30 ≥ 100	h _{nom} + 30 ≥ 100	h _{nom} + 30 ≥ 100	h _{nom} + 2d ₀	h _{nom} + 2d ₀	h _{nom} + 2d ₀	h _{nom} + 2d ₀
Installation torque	T _{inst}	[Nm]	10	20	40	80	120	180	200
Min. spacing	s _{min}	[mm]	40	40	40	50	60	70	85
Min. edge distance	c _{min}	[mm]	40	40	40	50	60	70	85
MINIMUM EMBEDMENT DEPTH									
Installation depth	h _{nom, min}	[mm]	60	70	80	100	120	140	165
MAXIMUM EMBEDMENT DEPTH									
Installation depth	h _{nom, max}	[mm]	160	200	240	320	400	480	600

Minimum working and curing time

Resin temperature	Concrete temperature	Curing time*	Working time
[°C]	[°C]	[min]	[min]
5	5	150	2880
10	10	120	1080
20	20	35	480
25	30	12	300

Mechanical properties

Size	M8	M10	M12	M16	M20	M24	M30
R-STUDS Metric Threaded Rods - Steel Class 5.8							
Nominal ultimate tensile strength - tension	f _{uk}	[N/mm ²]	500	500	500	500	500
Nominal yield strength - tension	f _{yk}	[N/mm ²]	400	400	400	400	400
Cross sectional area - tension	A _s	[mm ²]	36.6	58	84.3	157	352.8
Elastic section modulus	W _{el}	[mm ³]	31.2	62.3	109.2	277.5	541
Characteristic bending resistance	M ⁰ _{Rk,s}	[Nm]	19	37	65	166	324
Design bending resistance	M	[Nm]	15	30	52	133	259
Allowable bending resistance	M _{rec}	[Nm]	11	21	37	95	185

Mechanical properties

Size			M8	M10	M12	M16	M20	M24	M30
R-STUDS Metric Threaded Rods - Steel Class 8.8									
Nominal ultimate tensile strength - tension	f_{uk}	[N/mm ²]	800	800	800	800	800	800	800
Nominal yield strength - tension	f_{yk}	[N/mm ²]	640	640	640	640	640	640	640
Cross sectional area - tension	A_s	[mm ²]	36.6	58	84.3	157	245	352.8	559.8
Elastic section modulus	W_{el}	[mm ³]	31.2	62.3	109.2	277.5	541	935	1868
Characteristic bending resistance	$M_{Rk,s}^0$	[Nm]	30	60	105	266	519	898	1799
Design bending resistance	M	[Nm]	24	48	84	213	416	718	1439
Allowable bending resistance	M_{rec}	[Nm]	17	34	60	152	297	513	1028
R-STUDS Metric Threaded Rods - A4									
Nominal ultimate tensile strength - tension	f_{uk}	[N/mm ²]	700	700	700	700	700	700	700
Nominal yield strength - tension	f_{yk}	[N/mm ²]	350	350	350	350	350	350	350
Cross sectional area - tension	A_s	[mm ²]	36.6	58	84.3	157	245	352.8	559.8
Elastic section modulus	W_{el}	[mm ³]	31.2	62.3	109.2	277.5	541	935	1868
Characteristic bending resistance	$M_{Rk,s}^0$	[Nm]	26	52	92	233	454	786	1574
Design bending resistance	M	[Nm]	17	34	59	149	291	504	1009
Allowable bending resistance	M_{rec}	[Nm]	12	24	42	107	208	360	721

Basic performance data

R-STUDS

Performance data for single anchor without influence of edge distance and spacing - ETAG 001

Size		M8	M10	M12	M16	M20	M24	M30	M8	M10	M12	M16	M20	M24	M30
Substrate		Non-cracked concrete						Cracked concrete							
MEAN ULTIMATE LOAD															
TENSION LOAD $N_{Ru,m}$															
R-STUDS METRIC THREADED RODS - STEEL CLASS 5.8															
Minimum embedment depth	[kN]	18.9	30.5	44.1	67.5	88.7	111.8	143.1	18.9	27.8	34.0	47.5	62.4	76.7	100.7
Maximum embedment depth	[kN]	18.9	30.5	44.1	81.9	128.1	184.8	294.0	18.9	30.5	44.1	81.9	128.1	184.8	294.0
R-STUDS METRIC THREADED RODS - STEEL CLASS 8.8															
Minimum embedment depth	[kN]	28.7	39.5	48.3	67.5	88.7	111.8	143.1	22.1	27.8	34.0	47.5	62.4	76.7	100.7
Maximum embedment depth	[kN]	30.5	48.3	70.4	132.3	205.8	296.1	471.1	30.5	48.3	70.4	132.3	205.8	196.1	471.5
R-STUDS METRIC THREADED RODS - A4															
Minimum embedment depth	[kN]	27.3	39.5	48.3	67.5	88.7	111.8	143.1	22.1	27.8	34.0	47.5	62.4	76.7	100.7
Maximum embedment depth	[kN]	27.3	43.1	62.0	115.5	179.6	259.4	412.7	27.3	43.1	62.0	115.5	179.6	259.4	412.7
SHEAR LOAD $V_{Ru,m}$															
R-STUDS METRIC THREADED RODS - STEEL CLASS 5.8															
Minimum embedment depth	[kN]	11.3	18.3	26.5	49.1	76.9	110.9	176.4	11.3	18.3	26.5	49.1	76.9	110.9	176.4
Maximum embedment depth	[kN]	11.3	18.3	26.5	49.1	76.9	110.9	176.4	11.3	18.3	26.5	49.1	76.9	110.9	176.4
R-STUDS METRIC THREADED RODS - STEEL CLASS 8.8															
Minimum embedment depth	[kN]	18.3	29.0	42.2	79.4	123.5	177.7	282.9	18.3	29.0	42.2	79.4	123.5	153.4	201.4
Maximum embedment depth	[kN]	18.3	29.0	42.2	79.4	123.5	177.7	282.9	18.3	29.0	42.2	79.4	123.5	177.7	282.9
R-STUDS METRIC THREADED RODS - A4															
Minimum embedment depth	[kN]	16.4	16.4	37.2	69.3	107.7	155.6	247.6	16.4	25.8	31.2	69.3	107.7	155.6	201.4
Maximum embedment depth	[kN]	16.4	16.4	37.2	69.3	107.7	155.6	247.6	16.4	25.8	31.2	69.3	107.7	155.6	247.6

Basic performance data

Size		M8	M10	M12	M16	M20	M24	M30	M8	M10	M12	M16	M20	M24	M30
CHARACTERISTIC LOAD															
TENSION LOAD N_{Rk}															
R-STUDS METRIC THREADED RODS - STEEL CLASS 5.8															
Minimum embedment depth	[kN]	18.0	29.0	36.1	50.5	66.4	83.7	107.0	12.1	17.6	21.1	35.2	47.3	59.6	76.3
Maximum embedment depth	[kN]	18.0	29.0	42.0	78.0	122.0	176.0	280.0	18.0	29.0	42.0	78.0	122.0	176.0	280.0
R-STUDS METRIC THREADED RODS - STEEL CLASS 8.8															
Minimum embedment depth	[kN]	23.5	29.6	36.1	50.5	66.4	83.7	107.0	12.1	17.6	21.1	35.2	47.3	59.6	76.3
Maximum embedment depth	[kN]	29.0	46.0	67.0	126.0	196.0	282.0	449.0	29.0	46.0	63.3	112.6	175.9	217.2	282.7
R-STUDS METRIC THREADED RODS - A4															
Minimum embedment depth	[kN]	23.5	29.6	36.1	50.5	66.4	83.7	107.0	12.1	17.6	21.1	35.2	47.3	59.6	76.3
Maximum embedment depth	[kN]	26.0	41.0	59.0	110.0	171.0	247.0	393.0	26.0	41.0	59.0	110.0	171.0	217.2	282.7
SHEAR LOAD V_{Rk}															
R-STUDS METRIC THREADED RODS - STEEL CLASS 5.8															
Minimum embedment depth	[kN]	9.00	14.0	21.0	39.0	61.0	88.0	140.0	9.00	14.0	21.0	39.0	61.0	88.0	140.0
Maximum embedment depth	[kN]	9.00	14.0	21.0	39.0	61.0	88.0	140.0	9.00	14.0	21.0	39.0	61.0	88.0	140.0
R-STUDS METRIC THREADED RODS - STEEL CLASS 8.8															
Minimum embedment depth	[kN]	15.0	23.0	34.0	63.0	98.0	141.0	214.1	15.0	23.0	34.0	63.0	94.7	119.3	152.6
Maximum embedment depth	[kN]	15.0	23.0	34.0	63.0	98.0	141.0	224.0	15.0	23.0	34.0	63.0	98.0	141.0	224.0
R-STUDS METRIC THREADED RODS - A4															
Minimum embedment depth	[kN]	13.0	20.0	29.0	55.0	86.0	124.0	196.0	13.0	20.0	29.0	55.0	86.0	119.3	152.6
Maximum embedment depth	[kN]	13.0	20.0	29.0	55.0	86.0	124.0	196.0	13.0	20.0	29.0	55.0	86.0	124.0	196.0
DESIGN LOAD															
TENSION LOAD N_{Rd}															
R-STUDS METRIC THREADED RODS - STEEL CLASS 5.8															
Minimum embedment depth	[kN]	12.0	19.3	24.1	33.7	44.3	55.8	71.4	8.04	11.7	14.1	23.5	31.6	39.8	50.9
Maximum embedment depth	[kN]	12.0	19.3	28.0	52.0	81.3	117.3	186.7	12.0	19.3	28.0	52.0	81.3	117.3	186.7
R-STUDS METRIC THREADED RODS - STEEL CLASS 8.8															
Minimum embedment depth	[kN]	15.7	19.7	24.1	33.7	44.3	55.8	71.4	8.04	11.7	14.1	23.5	31.6	39.8	50.9
Maximum embedment depth	[kN]	19.3	30.7	44.7	84.0	130.7	188.0	299.3	19.3	30.7	42.2	75.1	117.3	144.8	188.5
R-STUDS METRIC THREADED RODS - A4															
Minimum embedment depth	[kN]	13.9	19.7	24.1	33.7	44.3	55.8	71.4	8.04	11.7	14.1	23.5	31.6	39.8	50.9
Maximum embedment depth	[kN]	13.9	21.9	31.6	58.8	91.4	132.1	210.2	13.9	21.9	31.6	58.8	91.4	132.1	188.5
SHEAR LOAD V_{Rd}															
R-STUDS METRIC THREADED RODS - STEEL CLASS 5.8															
Minimum embedment depth	[kN]	7.20	11.2	16.8	31.2	48.8	70.4	112.0	7.20	11.2	16.8	31.2	48.8	70.4	101.7
Maximum embedment depth	[kN]	7.20	11.2	16.8	31.2	48.8	70.4	112.0	7.20	11.2	16.8	31.2	48.8	70.4	112.0
R-STUDS METRIC THREADED RODS - STEEL CLASS 8.8															
Minimum embedment depth	[kN]	12.0	18.4	27.2	50.4	78.4	111.5	142.7	12.0	18.4	27.2	46.9	63.1	79.5	101.7
Maximum embedment depth	[kN]	12.0	18.4	27.2	50.4	78.4	112.8	179.2	12.0	18.4	27.2	50.4	78.4	112.8	179.2
R-STUDS METRIC THREADED RODS - A4															
Minimum embedment depth	[kN]	8.33	12.8	18.6	35.3	55.1	79.5	125.6	8.33	12.8	18.6	35.3	55.1	79.5	101.7
Maximum embedment depth	[kN]	8.33	12.8	18.6	35.3	55.1	79.5	125.6	8.33	12.8	18.6	35.3	55.1	79.5	125.6

Basic performance data

Size		M8	M10	M12	M16	M20	M24	M30	M8	M10	M12	M16	M20	M24	M30
RECOMMENDED LOAD															
TENSION LOAD N_{rec}															
R-STUDS METRIC THREADED RODS - STEEL CLASS 5.8															
Minimum embedment depth	[kN]	8.57	13.8	17.2	24.1	31.6	39.8	51.0	5.74	8.38	10.1	16.8	22.5	28.4	36.3
Maximum embedment depth	[kN]	8.57	13.8	20.0	37.1	58.1	83.8	133.3	8.57	13.8	20.0	37.1	58.1	83.8	133.3
R-STUDS METRIC THREADED RODS - STEEL CLASS 8.8															
Minimum embedment depth	[kN]	11.2	14.1	17.2	24.1	31.6	39.8	51.0	5.74	8.38	10.1	16.8	22.5	28.4	36.3
Maximum embedment depth	[kN]	13.8	21.9	31.9	60.0	93.3	134.3	213.8	13.8	21.9	30.2	55.6	83.8	103.4	134.6
R-STUDS METRIC THREADED RODS - A4															
Minimum embedment depth	[kN]	9.93	14.1	17.2	24.1	31.6	39.8	51.0	5.74	8.38	10.1	16.8	22.5	28.4	36.3
Maximum embedment depth	[kN]	9.93	15.7	22.5	42.0	65.3	94.4	150.1	9.93	15.7	22.5	42.0	65.3	94.4	134.6
SHEAR LOAD V_{rec}															
R-STUDS METRIC THREADED RODS - STEEL CLASS 5.8															
Minimum embedment depth	[kN]	5.14	8.00	12.0	22.3	34.9	50.3	80.0	5.14	8.00	12.0	22.3	34.9	50.3	72.7
Maximum embedment depth	[kN]	5.14	8.00	12.0	22.3	34.9	50.3	80.0	5.14	8.00	12.0	22.3	34.9	50.3	80.0
R-STUDS METRIC THREADED RODS - STEEL CLASS 8.8															
Minimum embedment depth	[kN]	8.57	13.1	19.4	36.0	56.0	79.7	101.9	8.57	13.1	19.4	33.5	45.1	56.8	72.7
Maximum embedment depth	[kN]	8.57	13.1	19.4	36.0	56.0	80.6	128.0	8.57	13.1	19.4	36.0	56.0	80.6	128.0
R-STUDS METRIC THREADED RODS - A4															
Minimum embedment depth	[kN]	5.95	9.16	13.3	25.2	39.4	56.8	89.7	5.95	9.16	13.3	25.2	39.4	56.8	72.7
Maximum embedment depth	[kN]	5.95	9.16	13.3	25.2	39.4	56.8	89.7	5.95	9.16	13.3	25.2	39.4	56.8	89.7

Design performance data

R-STUDS

Size			M8	M10	M12	M16	M20	M24	M30
TENSION LOAD									
STEEL FAILURE; STEEL CLASS 5.8									
Characteristic resistance	$N_{Rk,s}$	[kN]	18.00	29.00	42.00	78.00	122.00	176.00	280.00
Partial safety factor	γ_{Ms}	-	1.50	1.50	1.50	1.50	1.50	1.50	1.50
STEEL FAILURE; STEEL CLASS 8.8									
Characteristic resistance	$N_{Rk,s}$	[kN]	29.00	46.00	67.00	126.00	196.00	282.00	448.00
Partial safety factor	γ_{Ms}	-	1.50	1.50	1.50	1.50	1.50	1.50	1.50
STEEL FAILURE; STEEL GRADE A4-70									
Characteristic resistance	$N_{Rk,s}$	[kN]	26.00	41.00	59.00	110.00	171.00	247.00	392.00
Partial safety factor	γ_{Ms}	-	1.87	1.87	1.87	1.87	1.87	1.87	1.87
COMBINED PULL-OUT AND CONCRETE CONE FAILURE; NON-CRACKED CONCRETE, C20/25 (40°C/24°C)									
Characteristic bond resistance	T_{Rk}	[N/mm ²]	17.00	16.00	17.00	15.00	15.00	13.00	12.00
COMBINED PULL-OUT AND CONCRETE CONE FAILURE; NON-CRACKED CONCRETE, C20/25 (80°C/50°C)									
Characteristic bond resistance	T_{Rk}	[N/mm ²]	15.00	14.00	15.00	13.00	13.00	12.00	10.00
COMBINED PULL-OUT AND CONCRETE CONE FAILURE; CRACKED CONCRETE, C20/25 (40°C/24°C)									
Characteristic bond resistance	T_{Rk}	[N/mm ²]	8.00	8.00	7.00	7.00	7.00	6.00	5.00
COMBINED PULL-OUT AND CONCRETE CONE FAILURE; CRACKED CONCRETE, C20/25 (80°C/50°C)									
Characteristic bond resistance	T_{Rk}	[N/mm ²]	7.00	7.00	6.00	6.00	6.00	5.00	4.00
COMBINED PULL-OUT AND CONCRETE CONE FAILURE									
Installation safety factor	γ_2	-	1.00	1.00	1.00	1.00	1.00	1.00	1.00
Increasing factors for $N_{Rd,p}$ - C30/37	ψ_c	-	1.04	1.04	1.04	1.04	1.04	1.04	1.04
Increasing factors for $N_{Rd,p}$ - C40/50	ψ_c	-	1.07	1.07	1.07	1.07	1.07	1.07	1.07
Increasing factors for $N_{Rd,p}$ - C50/60	ψ_c	-	1.09	1.09	1.09	1.09	1.09	1.09	1.09
CONCRETE CONE FAILURE									
Installation safety factor	γ_2	-	1.00	1.00	1.00	1.00	1.00	1.00	1.00
Factor for cracked concrete	k	-	7.20	7.20	7.20	7.20	7.20	7.20	7.20
Factor for cracked concrete	$k_{cr,N}$	-	7.70	7.70	7.70	7.70	7.70	7.70	7.70
Factor for non-cracked concrete	k	-	10.10	10.10	10.10	10.10	10.10	10.10	10.10
Factor for non-cracked concrete	$k_{ucr,N}$	-	11.00	11.00	11.00	11.00	11.00	11.00	11.00
Edge distance	$c_{cr,N}$	[mm]	1.5* h_{ef}	1.5* h_{ef}	1.5* h_{ef}	1.5* h_{ef}	1.5* h_{ef}	1.5* h_{ef}	1.5* h_{ef}
Spacing	$s_{cr,N}$	[mm]	3.0* h_{ef}	3.0* h_{ef}	3.0* h_{ef}	3.0* h_{ef}	3.0* h_{ef}	3.0* h_{ef}	3.0* h_{ef}
CONCRETE SPLITTING FAILURE									
Installation safety factor	γ_2	-	1.00	1.00	1.00	1.00	1.00	1.00	1.00

Design performance data

Size			M8	M10	M12	M16	M20	M24	M30
SHEAR LOAD									
STEEL FAILURE; STEEL CLASS 5.8									
Characteristic resistance without lever arm	$V_{Rk,s}$	[kN]	9.00	14.00	21.00	39.00	61.00	88.00	140.00
Ductility factor	k_{γ}	-	0.80	0.80	0.80	0.80	0.80	0.80	0.80
Characteristic resistance with lever arm	$M_{Rk,s}$	[Nm]	19.00	37.00	65.00	166.00	324.00	561.00	1124.00
Partial safety factor	γ_{Ms}	-	1.25	1.25	1.25	1.25	1.25	1.25	1.25
STEEL FAILURE; STEEL CLASS 8.8									
Characteristic resistance without lever arm	$V_{Rk,s}$	[kN]	15.00	23.00	34.00	63.00	98.00	141.00	224.00
Ductility factor	k_{γ}	-	0.80	0.80	0.80	0.80	0.80	0.80	0.80
Characteristic resistance with lever arm	$M_{Rk,s}$	[Nm]	30.00	60.00	105.00	266.00	519.00	898.00	1799.00
Partial safety factor	γ_{Ms}	-	1.25	1.25	1.25	1.25	1.25	1.25	1.25
STEEL FAILURE; STEEL GRADE A4-70									
Characteristic resistance without lever arm	$V_{Rk,s}$	[kN]	13.00	20.00	29.00	55.00	86.00	124.00	196.00
Ductility factor	k_{γ}	-	0.80	0.80	0.80	0.80	0.80	0.80	0.80
Characteristic resistance with lever arm	$M_{Rk,s}$	[Nm]	26.00	52.00	92.00	233.00	454.00	786.00	1574.00
Partial safety factor	γ_{Ms}	-	1.56	1.56	1.56	1.56	1.56	1.56	1.56
CONCRETE PRY-OUT FAILURE									
Factor	k	-	2.00	2.00	2.00	2.00	2.00	2.00	2.00
Installation safety factor	γ_2	-	1.00	1.00	1.00	1.00	1.00	1.00	1.00
CONCRETE EDGE FAILURE									
Anchor diameter	d_{nom}	[mm]	8.00	10.00	12.00	16.00	20.00	24.00	30.00
Effective length of anchor	ℓ_f	[mm]	min ($h_{ef}; 8d_{nom}$)	min ($h_{ef}; 8d_{nom}$)	min ($h_{ef}; 8d_{nom}$)	min ($h_{ef}; 8d_{nom}$)	min ($h_{ef}; 8d_{nom}$)	min ($h_{ef}; 8d_{nom}$)	min ($h_{ef}; 8d_{nom}$)
Installation safety factor	γ_2	-	1.00	1.00	1.00	1.00	1.00	1.00	1.00

Combined pull-out and concrete cone failure (TR 029, p.5.2.2.3. acc. to formula 5.2a - $N_{Rk,p}^0 = n \cdot d \cdot h_{ef} \cdot \tau_{Rk}$).

Concrete cone failure (TR 029, p.5.2.2.4. acc. to formula 5.3a - $N_{Rk,c}^0 = k_1 \cdot f_{ck,cube}^{0.5} \cdot h_{ef}^{1.5}$).

$h_{ef} = h_{nom}$

Product commercial data

Size	Product Code	Volume [m ³]	Quantity [pcs]			Weight [kg]			Bar Codes
			Box	Outer	Pallet	Box	Outer	Pallet	
M8	R-KEX-II-385 ¹⁾	385	10	10	380	6.7	6.7	285.0	5906675028538
M30	R-KEX-II-600 ¹⁾	600	7	7	441	7.0	7.0	472.7	5906675293721

1) ETA-13/0455